

## Timing Gear

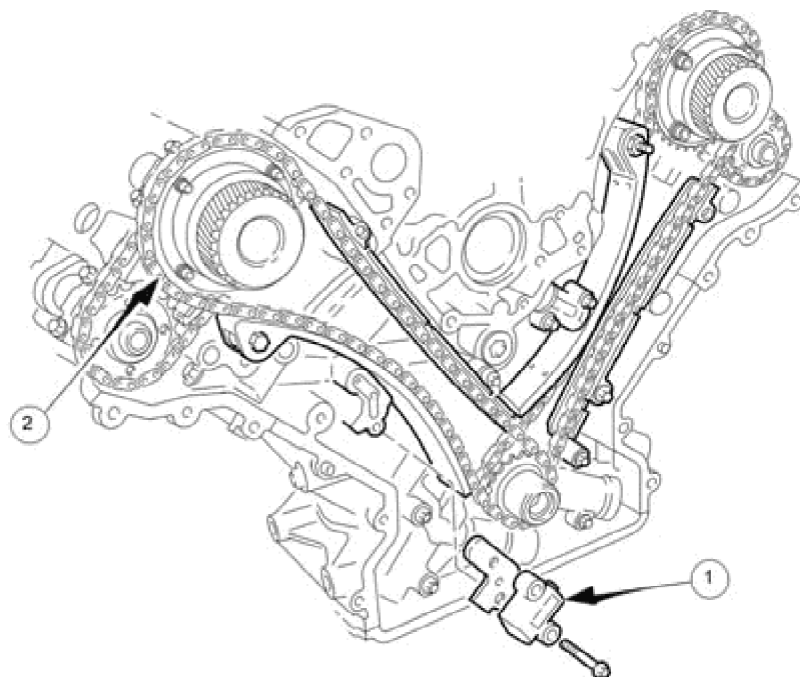

J3031263

Item	Description
1	Primary Chain Tensioner
2	Primary Chain

Single row primary and secondary chains drive the camshafts of each cylinder bank. The primary chains transmit the drive from two sprockets on the crankshaft to a sprocket on each intake camshaft. The secondary chains transmit the drive from a second, smaller sprocket on the intake camshaft to a sprocket on the exhaust camshaft.

Each chain has a hydraulic tensioner operated by the engine lubricating system. A jet of oil from the end of each tensioner lubricates the chains. The primary chain tensioners act on pivoting flexible tensioner blades, the secondary chain tensioners act directly on the chains. Guide rails are used on the drive side of the primary chains.

A key locates the two drive sprockets on the crankshaft and these are retained in position by the crankshaft torsional vibration damper.

# 1999 XK RANGE - Basic Engine - 303-01

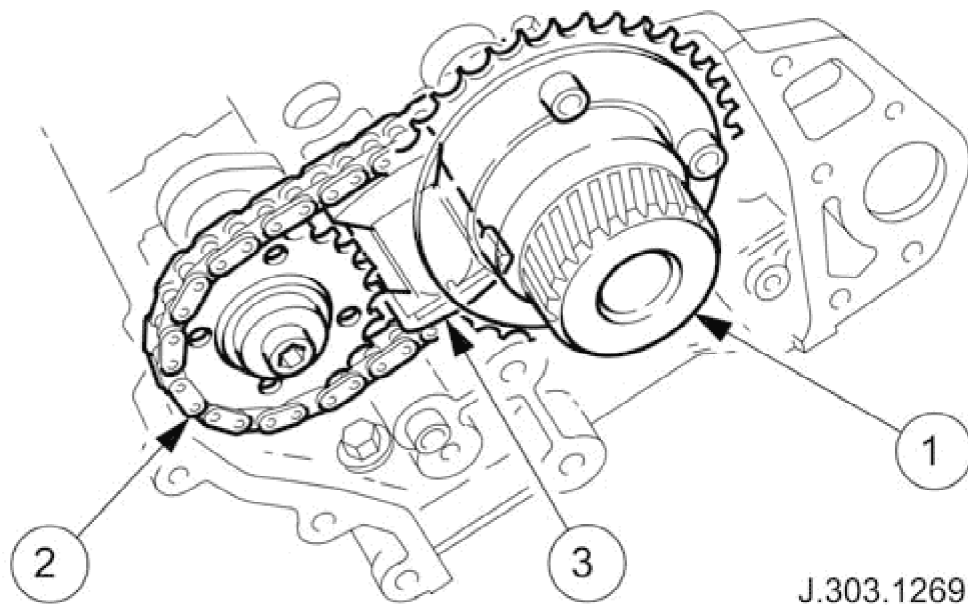

## Parts List

Item	Description
1	Variable Valve Timing Unit, where fitted
2	Secondary Chain
3	Secondary Chain Tensioner

The variable valve timing units and the exhaust camshaft sprockets are a non-interference, non-keyed fit on their respective camshafts. They are clamped in place on the camshafts by the securing bolt and clamping plate/washer.

## Timing Cover

# 1999 XK RANGE - Basic Engine - 303-01

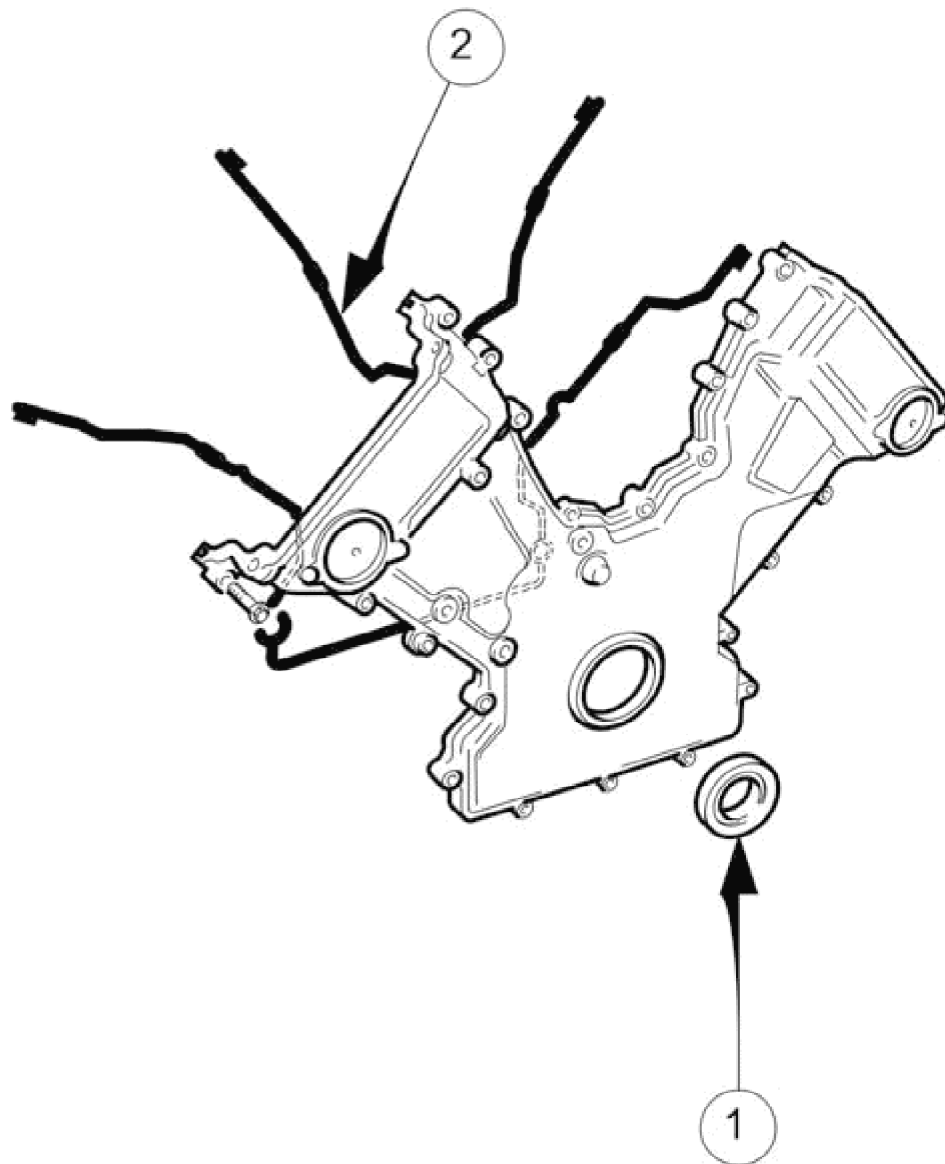

J.303.1250

## Parts List

Item	Description
1	Crankshaft Front Oil Seal
2	Silicon Rubber Gaskets

The aluminium-alloy timing cover accommodates the crankshaft front oil seal. Silicon rubber in-groove gaskets seal the joint between the timing cover and the front face of the engine.